



Series 1400 Skylights

Product Data Sheet



Application

The skylight shall be fully factory assembled, consisting of an acrylic dome with a CC2 classification that is sealed by interior and exterior gaskets. The skylight frame is fabricated from 6063-T5 heliarc welded aluminum which has an integral condensate channel. The aluminum retaining cap fasteners are corrosion resistant. A polyurethane thermal break is utilized in the thermally broken curb frame to prevent thermal losses through the frame and the formation of condensation on its interior surfaces. The thermally broken self flashing base is fabricated from aluminum with a 2-3/4" roof nailing flange and 1" of insulation inside a PVC frame with a white aluminum liner on the interior. The insulated aluminum self flashing curb has a 2-3/4" roof nailing flange.

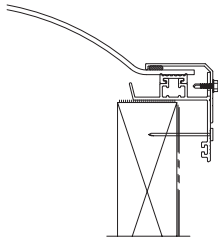

AL - Aluminum framed skylight. Available as curb mounted or self flashing.

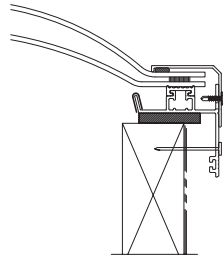

ALB - Aluminum framed skylight with Polyvinyl Chloride (PVC) thermal barrier. Available as curb mounted only. (Shown with optional curb seal tape)

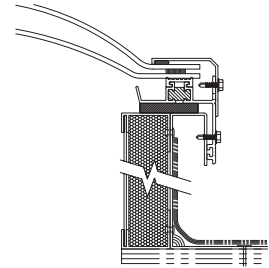

ALT - Thermally broken aluminum framed skylight. Available as curb mounted or self flashing. (Self flashing model shown)

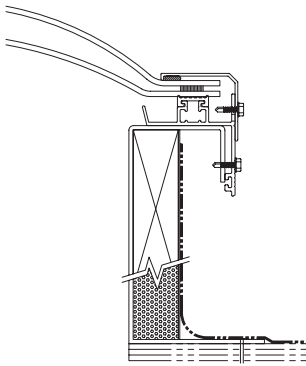

ALI - Aluminum framed skylight with insulated base. Available as self flashing only. (Shown with optional wood nailer and aluminum double wall)

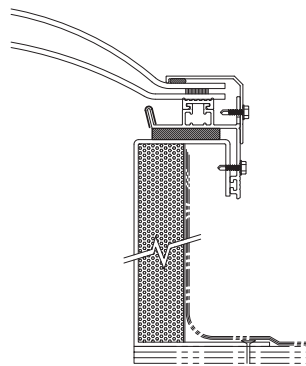

ALIB - Aluminum framed skylight with Polyvinyl Chloride (PVC) thermal barrier and insulated base. Available as self flashing only. (Shown with optional curb seal tape and aluminum double wall)

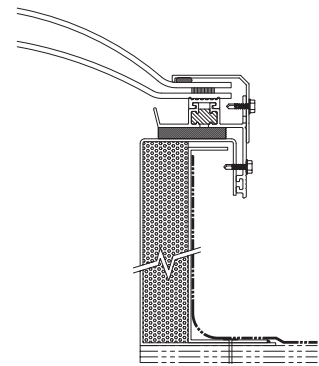

ALIT - Thermally broken aluminum framed skylight with insulated base. Available as self flashing only. (Shown with optional curb seal tape and aluminum welded double wall)

Dimensions

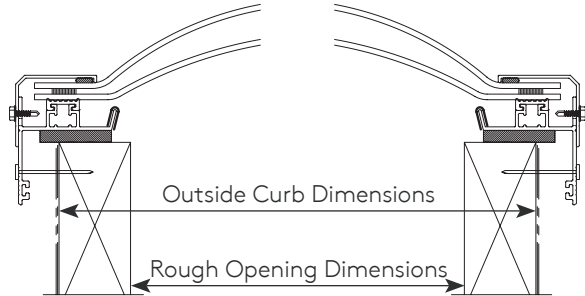

Curb Mounted

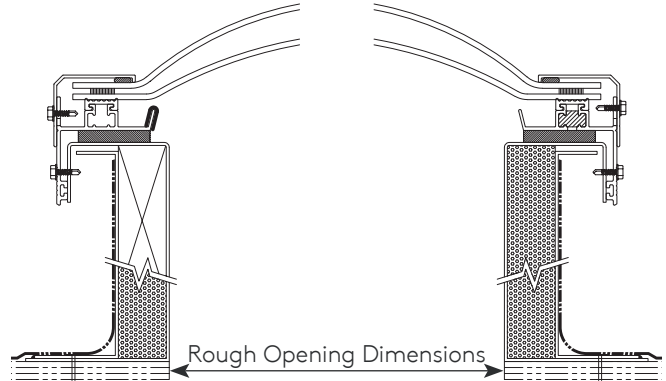

Self Flashing

Model Size	Rough Opening Dimensions	Outside Curb Dimensions	Model Size	Rough Opening Dimensions	Outside Curb Dimensions
1414	14-1/4" x 14-1/4"	17-1/4" x 17-1/4"	1422	14-1/4" x 22-1/4"	17-1/4" x 25-1/4"
1919	19" x 19"	22" x 22"	1446	14-1/4" x 46-1/4"	17-1/4" x 49-1/4"
2222	22-1/4" x 22-1/4"	25-1/4" x 25-1/4"	2230	22-1/4" x 30-1/4"	25-1/4" x 34-1/4"
3030	30-1/4" x 30-1/4"	33-1/4" x 33-1/4"	2237	22-1/4" x 37"	25-1/4" x 40"
3737	37" x 37"	40" x 40"	2246	22-1/4" x 46-1/4"	25-1/4" x 49-1/4"
4242	42" x 42"	45" x 45"	2272	22-1/4" x 72"	25-1/4" x 75"
4646	46-1/4" x 46-1/4"	49-1/4" x 49-1/4"	2296	22-1/4" x 96"	25-1/4" x 99"
4848	48" x 48"	51" x 51"	3046	30-1/4" x 46-1/4"	33-1/4" x 49-1/4"
5555	55" x 55"	58" x 58"	3069	30-1/4" x 69-1/2"	33-1/4" x 72-1/2"
6060	60" x 60"	63" x 63"	3746	37" x 46-1/4"	40" x 49-1/4"
7070 ¹	70-1/4" x 70-1/4"	73-1/4" x 73-1/4"	3775	37" x 75"	40" x 78"
7575 ¹	75" x 75"	78" x 78"	3859	38" x 59"	41" x 62"
9292 ¹	92-1/2" x 92-1/2"	95-1/2" x 95-1/2"	4669	46-1/4" x 69-1/2"	49-1/4" x 72-1/2"
			4689	46-1/4" x 89-1/2"	49-1/4" x 92-1/2"
			4884	48" x 84"	51" x 87"
			4896	48" x 96"	51" x 99"
			6096 ¹	60" x 96"	63" x 99"

¹ Only available in heavy duty "ALHD" frame.

Technical Specifications

Combustion Classification

CC2

Example Model Number

4896-ALI-SF-2-WTM/CC-MF-12-INS-WN

Features

1. Extruded 6063-T5 aluminum frame with mill finish
2. Curb mounted (CM), Curb mounted with EPDM tape (CT) or Self flashing (SF)
3. Bubble shaped monolithic acrylic glazing
4. 2-3/4" nailing flange (self flashing models only)
5. Santoprene thermoplastic gaskets
6. Black butyl retainer cap sealant
7. Polyurethane glazing sealants

Skylight Options

1. Three skylight frame designs:
 - a. Extruded aluminum frame (AL)
 - b. Extruded aluminum frame with thermal barrier material (ALB)
 - c. Poured & debridged thermally broken extruded aluminum frame (ALT)
2. Single (1) or double (2) glazed
3. Standard glazing options*:
 - a. Bronze monolithic acrylic (BT)
 - b. Clear monolithic acrylic (CC)
 - c. White monolithic acrylic (WTM)

Self Flashing Curb Options

1. Curb heights*:
 - a. 4"
 - b. 9"
 - c. 12"

*Custom heights available upon request
2. Insulated curb (INS)
3. Wood nailer (WN)
4. Non-welded double wall (DW)
5. Welded double wall (WDW)
6. Aluminum termination bar (TB)

Accessories

1. Roof Safety
 - a. External safety cages (SCAGE)
 - b. Safety screens (SSCRN)
 - c. Security grills (SG)

Warranty

For a period of ten (10) years from the date of purchase, Kingspan Light + Air warrants that the Series 1400 skylight will be free of defects in material and workmanship and there will be no uncontrolled water leakage through the commercial fixed curb mount or self flashed skylight. Exceptions do apply. Please see full 10-Year warranty document for more details.

IMPORTANT SAFETY NOTE:

The owner must take steps to protect personnel who may be in the area of the skylight or smoke vent. The owner should restrict access only to authorized personnel who have been adequately cautioned as to the location of the skylights or smoke vents and informed of the warnings below. Because there is a risk of fall and resulting personal injury, we recommend protective guardrails, internal safety screens or external cages around all skylights and smoke vents, as well as the use of fall restraint systems. We also recommend that skylights and smoke vents are inspected annually for evidence of damage, such as cracks or penetrations. Any damage should be repaired immediately, and the area beneath the skylight or smoke vent should be safeguarded against falling objects.

Kingspan Light + Air

North American Headquarters

28662 N. Ballard Dr.

Lake Forest, IL 60045

Toll Free: +1 800 759 6985

T: +1 847 816 1060

F: +1 847 816 0425

E: info@kingspanlightandair.us

www.kingspanlightandair.us



To ensure you are viewing the most recent and accurate product information, please scan the QR code above

Care has been taken to ensure that the contents of this publication are accurate, but Kingspan Limited and its subsidiary companies do not accept responsibility for errors or for information that is found to be misleading. Suggestions for, or description of, the end use or application of products or methods of working are for information only and Kingspan Limited and its subsidiaries accept no liability in respect thereof.

For the product offering in other markets please contact your local sales representative or visit kingspan.com

© Kingspan and the Lion Device are Registered Trademarks of the Kingspan Group plc in the US, Canada and other countries.

© Kingspan Light + Air