



# Series 3200 UL Listed Smoke Vent Product Data Sheet



# Application

Series 3200 smoke vents are available in acrylic glazing with galvanized steel or aluminum frames. Doors are compression loaded by a spring and secured on the opposite side with latches operated either manually, or by a single fusible link. Doors shall open against a 30psf uniform load and shall withstand a uniform 10psf load in the open and locked position. Doors and spring actuated and equipped with heavy-duty shock absorbers to control the speed of operation. Units are designed to withstand a 30psf live or wind load in the closed position and a 30psf uplift load. Interior and exterior manual releases are available. All hardware shall be plated for corrosion resistance.

## Dimensions

Model Size	Rough Opening Dimensions	Outside Curb Dimensions	Model Size	Rough Opening Dimensions	Outside Curb Dimensions	Model Size	Rough Opening Dimensions	Outside Curb Dimensions
4848	48" x 48"	51" x 51"	4872	48" x 72"	51" x 75"	6072	60" x 72"	63" x 75"
6060	60" x 60"	63" x 63"	4896	48" x 96"	51" x 99"	6096	60" x 96"	63" x 99"

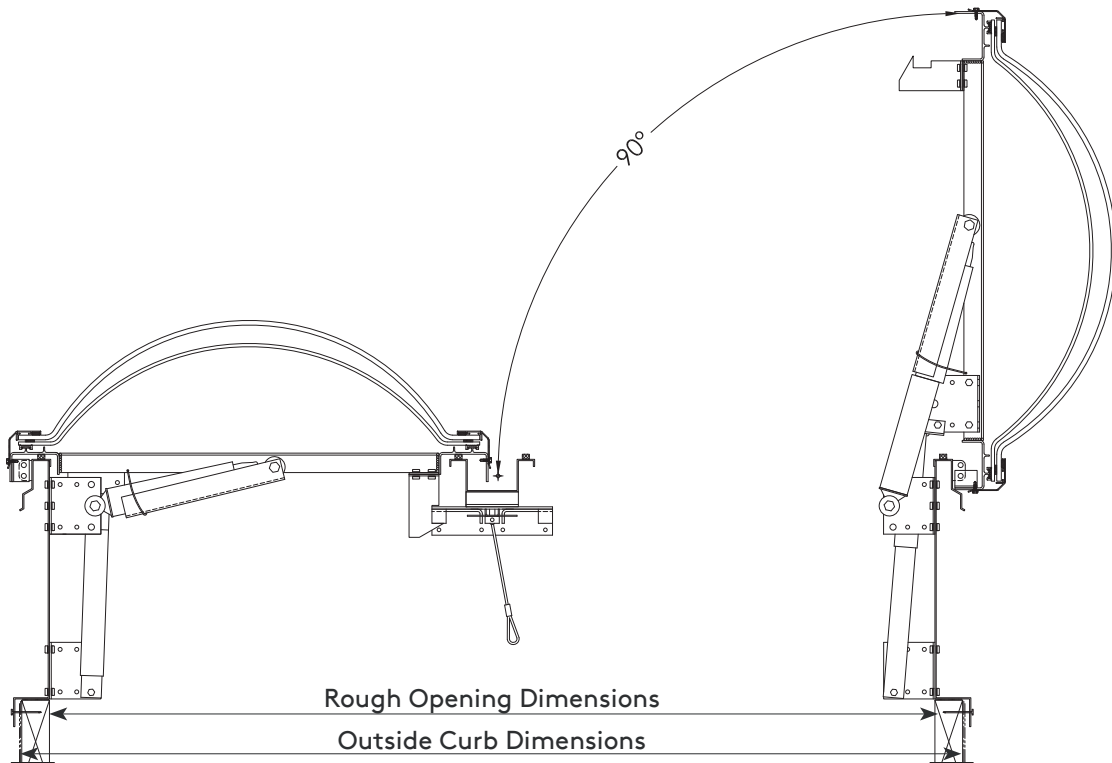

# Technical Specifications

Combustion Classification	CC2
Underwriters Laboratories (UL)	Listed to UL 793 Standards Wind Uplift Class: 30 Snow Load: 30 lbs

## Example Model Number

4896-SVAA-CM-1-WTM-B-M3-360-MF

## Frame options

1. Curb mounted (CM) or Self flashing (SF) with 4" nailing flange
2. Frame material
  - a. Aluminum (SVAA)
  - b. Galvanized steel (SVAM)

## Door options

1. Acrylic glazing
  - a. Single (1) or double (2) glazed
  - b. Clear or white monolithic acrylic

## Smoke Vent Options

1. EPDM curb seal tape (T)
2. Fusible link temperature options:
  - a. 165°
  - b. 212°
  - c. 286°
  - d. 360°
  - e. 520°
3. Mill finish frame (MF), as standard

## Self Flashing Curb Options

1. 12" Curb height, as standard
2. Insulated curb (INS)
3. Wood nailer (WN)
4. Non-welded double wall (DW)

## Accessories

1. Safety screens (SSCRN)
2. Security grills (SG)

## Warranty

For a period of ten (10) years from date of purchase, Kingspan Light + Air warrants that Series 3200 smoke vents will be free of defects in material and workmanship and no uncontrolled water leakage through the commercial fixed curb mount or self flashed smoke vent. Exceptions do apply. Please see full 10-Year Warranty document for more details.

## IMPORTANT SAFETY NOTE:

The owner must take steps to protect personnel who may be in the area of the skylight or smoke vent. The owner should restrict access only to authorized personnel who have been adequately cautioned as to the location of the skylights or smoke vents and informed of the warnings below. Because there is a risk of fall and resulting personal injury, we recommend protective guardrails, internal safety screens or external cages around all skylights and smoke vents, as well as the use of fall restraint systems. We also recommend that skylights and smoke vents are inspected annually for evidence of damage, such as cracks or penetrations. Any damage should be repaired immediately, and the area beneath the skylight or smoke vent should be safeguarded against falling objects.

---

## Kingspan Light + Air

### North American Headquarters

28662 N. Ballard Dr.

Lake Forest, IL 60045

Toll Free: +1 800 759 6985

T: +1 847 816 1060

F: +1 847 816 0425

E: [info@kingspanlightandair.us](mailto:info@kingspanlightandair.us)

[www.kingspanlightandair.us](http://www.kingspanlightandair.us)



To ensure you are viewing the most recent and accurate product information, please scan the QR code above

Care has been taken to ensure that the contents of this publication are accurate, but Kingspan Limited and its subsidiary companies do not accept responsibility for errors or for information that is found to be misleading. Suggestions for, or description of, the end use or application of products or methods of working are for information only and Kingspan Limited and its subsidiaries accept no liability in respect thereof.

For the product offering in other markets please contact your local sales representative or visit [kingspan.com](http://kingspan.com)

© Kingspan and the Lion Device are Registered Trademarks of the Kingspan Group plc in the US, Canada and other countries.

© Kingspan Light + Air

MKT-PDS-3200-2402

